

Wireless Conductivity Sensor with OLED Display

PS-4210

Introduction

The Wireless Conductivity Sensor with OLED Display measures conductivity over a range from 0 to 40,000 microsiemens per centimeter ($\mu\text{S}/\text{cm}$). The probe is able to work in a variety of solutions. The measurement is displayed at all times on the OLED display on the front of the sensor. You can also transmit the measurements (either wirelessly via Bluetooth or using the provided USB-C cable) to a connected tablet or computer, where they can be displayed and analyzed using PASCO Capstone, SPARKvue, or chemvue data collection software. Since each sensor has a unique device ID number, more than one sensor can be connected to a computer or tablet at the same time.

The Wireless Conductivity Sensor with OLED Display is powered by a rechargeable battery and is well-suited for both continuous recording and discrete measurements. The sensor is designed to optimize usage of the battery between recharging.

⚠ CAUTION: Do NOT immerse the sensor body in water or any other liquid! The housing is *not* waterproof, and exposing these components to liquid may result in electric shock or permanent damage to the sensor. Only 1-2 inches at the end of the probe need to be immersed in the liquid to obtain accurate conductivity measurements.

Components

Included components:

- Wireless Conductivity Sensor with OLED Display
- USB-C cable

Recommended software:

- PASCO Capstone, SPARKvue, or chemvue data collection software

Features

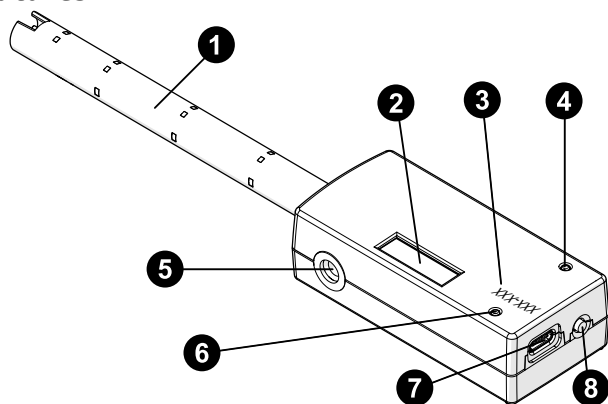

1 Probe

Tolerates temperatures in the range of 0 °C to 80 °C.

2 OLED display

Displays the conductivity measurement of the sensor at all times, refreshing at 1 second intervals.

3 Device ID number

Use to identify the sensor when connecting via Bluetooth.

4 Battery Status LED

Indicates the charge status of the sensor's rechargeable battery.

Battery LED	Status
Red blink	Low battery
Yellow ON	Charging
Green ON	Fully charged

5 Mounting rod hole

Use to mount the sensor to a 1/4-20 threaded rod, such as the Pulley Mounting Rod (SA-9242).

6 Bluetooth Status LED

Indicates the status of the sensor's Bluetooth connection.

Bluetooth LED	Status
Red blink	Ready to pair
Green blink	Connected
Yellow blink	Logging data (SPARKvue or Capstone only)

For information on remote data logging, see the PASCO Capstone or SPARKvue online help. (This feature is not available in chemvue.)

7 USB-C port

Charge the sensor by connecting this port to a standard USB charger via the included USB-C cable. You can also use this cable and port to connect the sensor to PASCO Capstone, SPARKvue, or chemvue without using Bluetooth.

8 Power button

Press to turn the sensor on. Briefly press and release twice in quick succession to toggle between different measurements on the OLED screen. Press and *hold* to turn the sensor off.

Background

Electrolytic conductivity is defined as the ability of a liquid to conduct electrical current. In conductive solvents, dissolved ions are the main conductors of electricity. By selecting the appropriate electrode, one can easily measure the electrical conductivity of liquids ranging from ultra-pure water to extremely salty solutions. How well a solution conducts electricity depends on the concentration, mobility, and valence of its ions, as well as the solution's temperature.

The Wireless Conductivity Sensor determines the electrical conductivity (EC) of a solution by measuring the alternating current (AC) flowing through a circuit when the AC signal is applied to a 2-cell electrode submerged in the solution.

Accurate conductivity measurements require all of the following:

- Absence of contamination in the solution
- Resistance of the electrodes to polarization
- Consistent electrode geometry (cell constant) between calibration and measurement
- Consistent temperature between calibration and measurement

Data from the Wireless Conductivity Sensor can be used to determine Total Dissolved Solids (TDS). The sensor measures and automatically compensates for temperature.

Sensor theory

Conductance is the reciprocal of resistance. Conductivity is the *specific conductance* of a material, or the conductance measured between the opposite faces of a one centimeter cube of the material.

The electrode cell in the end of the conductivity probe is constructed of an insulating material embedded with stainless steel pins. These metal contacts serve as sensing elements and are placed at fixed distances from each other.

Get the software

You can use the sensor with SPARKvue, PASCO Capstone, or chemvue software. If you're not sure which to use, visit [pasco.com/products/guides/software-comparison](https://www.pasco.com/products/guides/software-comparison).

A browser-based version of SPARKvue is available for free on all platforms. We offer a free trial of SPARKvue and Capstone for Windows and Mac. To get the software, go to [pasco.com/downloads](https://www.pasco.com/downloads) or search for **SPARKvue** or **chemvue** in your device's app store.

If you have installed the software previously, check that you have the latest update:

 **SPARKvue:** Main Menu  > Check for Updates

 **PASCO Capstone:** Help > Check for Updates

 **chemvue:** See the download page.

Check for a firmware update

SPARKvue

1. Press the power button until the LEDs turn on.
2. Open SPARKvue, then select **Sensor Data**  on the Welcome Screen.
3. From the list of available wireless devices, select the sensor that matches your sensor's device ID.
4. A notification will appear if a firmware update is available. Click **Yes** to update the firmware.
5. Close SPARKvue once the update is complete.

PASCO Capstone

1. Press the power button until the LEDs turn on.
2. Open PASCO Capstone and click **Hardware Setup**  from the Tools palette.
3. From the list of available wireless devices, select the sensor that matches your sensor's device ID.

4. A notification will appear if a firmware update is available. Click **Yes** to update the firmware.
5. Close Capstone once the update is complete.

chemvue

1. Press the power button until the LEDs turn on.
2. Open chemvue, then select the **Bluetooth**  button.
3. From the list of available wireless devices, select the sensor that matches your sensor's device ID.
4. A notification will appear if a firmware update is available. Click **Yes** to update the firmware.
5. Close chemvue once the update is complete.

Use the sensor without software

The Wireless Conductivity Sensor with OLED Display can be used without data collection software. To do so, simply turn on the sensor, place the probe into the sample to be tested, and observe the OLED display. The display will always show the most recent measurement from the probe, refreshing at 1 second intervals.

By default, the OLED display measures conductivity in units of $\mu\text{S}/\text{cm}$. However, if other measurements are desired, you can change the measurement using the power button. Quickly press and release the power button twice in succession to change the measurement from conductivity to temperature, as measured in degrees Celsius ($^{\circ}\text{C}$). From here, you can quickly press the button twice more to switch the units of temperature to degrees Fahrenheit ($^{\circ}\text{F}$), and then twice more to switch the measurement back to conductivity. The display will always cycle through the measurements in this order.

Set up the software

SPARKvue

Connecting the sensor to a tablet or computer via Bluetooth:

1. Turn on the Wireless Conductivity Sensor with OLED Display. Check to make sure the Bluetooth Status LED is blinking red.
2. Open SPARKvue, then click **Sensor Data**.
3. From the list of available wireless devices on the left, select the device which matches the device ID printed on your sensor.

Connecting the sensor to a computer via USB-C cable:

1. Open SPARKvue, then click **Sensor Data**.
2. Connect the provided USB-C cable from the USB-C port on the sensor to a USB port or powered USB hub connected to the computer. The sensor should automatically connect to SPARKvue.

Collecting data using SPARKvue:

1. Select the measurement you intend to record from the **Select measurements for templates** column by clicking the check box next to the relevant measurement's name.
2. Click **Graph** in the **Templates** column to open the Experiment Screen. The graph's axes will auto-populate with the selected measurement versus time.
3. Click **Start**  to begin collecting data.

PASCO Capstone



Connecting the sensor to a computer via Bluetooth:

1. Turn on the Wireless Conductivity Sensor with OLED Display. Check to make sure the Bluetooth Status LED is blinking red.
2. Open PASCO Capstone, then click **Hardware Setup**  in the **Tools** palette.
3. From the list of **Available Wireless Devices**, click the device which matches the device ID printed on your sensor.

Connecting the sensor to a computer via micro USB cable:

1. Open PASCO Capstone. If desired, click **Hardware Setup**  to check the connection status of the sensor.
2. Connect the provided USB-C cable from the USB-C port on the sensor to a USB port or powered USB hub connected to the computer. The sensor should automatically connect to Capstone.

Collecting data using Capstone:

1. Double-click the **Graph**  icon in the **Displays** palette to create a new blank graph display.
2. In the graph display, click the **<Select Measurement>** box on the y-axis and select an appropriate measurement from the list. The x-axis will automatically adjust to measure time.
3. Click **Record**  to begin collecting data.

chemvue



Connecting the sensor to a computer via Bluetooth:

1. Turn on the Wireless Conductivity Sensor with OLED Display. Check to make sure the Bluetooth Status LED is blinking red.
2. Open chemvue, then click the **Bluetooth**  button at the top of the screen.
3. From the list of available wireless devices, click the device which matches the device ID printed on your sensor.

Connecting the sensor to a computer via USB-C cable:

1. Open chemvue. If desired, click the **Bluetooth**  button to check the connection status of the sensor.
2. Connect the provided USB-C cable from the USB-C port on the sensor to a USB port or powered USB hub connected to the computer. The sensor should automatically connect to chemvue.

Collecting data using chemvue:

1. Open the **Graph**  display by selecting its icon from the navigation bar at the top of the page.
2. The display will automatically be set to plot conductivity versus time. If a different measurement is desired for either axis, click the box containing the default measurement's name and select the new measurement from the list.
3. Click **Start**  to begin collecting data.

Setting the ion coefficient

Electrical conductivity (EC), as measured in $\mu\text{S}/\text{cm}$, can be converted to Total Dissolved Solids (TDS) in parts per million (ppm) using an *ion coefficient*. This coefficient is determined by the ions in the solution, the specific mixture of which is frequently unknown. Any value from 0.01 to 0.99 is acceptable for the coefficient, with the ranges below recommended for specific solutions:

- 0.5 to 0.57 for potassium chloride (KCl), which is the most common calibration standard
- 0.45 to 0.5 for sodium chloride (NaCl), commonly used for testing brackish water and seawater
- 0.65 to 0.85 for the 442™ solution (40 % sodium bicarbonate, 40% sodium sulfate, and 20% sodium chloride) that is developed by the Myron L Company and used to simulate natural freshwater, such as rivers, lakes, and wells

The software's default coefficient is 0.65. The value of the coefficient is stored in the sensor. To change the ion coefficient, connect the sensor to your software of choice, as described previously, then follow the appropriate set of steps below.



SPARKvue:

1. From the **Sensor Data** screen, enable the measurement of Total Dissolved Solids.
2. Select a template to open the Experiment Screen.
3. From the bottom left of the Experiment Screen, click the **Live Data Bar** for Total Dissolved Solids, then select **Configure Sensor**.
4. Enter the appropriate value in the **Ion Coefficient** box.

PASCO Capstone:

1. From the **Hardware Setup** tool, click the **Properties**  button next to the Wireless Conductivity Sensor with OLED Display.
2. Enter the appropriate value in the **Ion Coefficient** box.

chemvue:

1. Click the **Configure Hardware**  button on the top right of the screen, then click the **Properties**  button next to the name of the Wireless Conductivity Sensor with OLED Display.
2. Enter the appropriate value in the **Ion Coefficient** box.

Sample conductivity values

This table provides the typical conductivity of common aqueous solutions at a temperature of 25 °C.

Solution	Conductivity ($\mu\text{S}/\text{cm}$)
Drinking water	50 to 1,000
Wastewater	900 to 9,000
KCl solution (0.01 M)	1,400
Potable water maximum	1,500
Brackish water	1,000 to 80,000
Industrial process water	3,000 to 140,000

Calibrating the sensor

The Wireless Conductivity Sensor with OLED Display is factory calibrated and does not require initial calibration. However, if desired, the sensor can be calibrated in SPARKvue, Capstone, or chemvue using two standard solutions of known conductivity. For instructions on calibrating the sensor, go to the SPARKvue, Capstone, or chemvue online help and search for "Calibrate a conductivity sensor".

Replace the battery

The battery compartment is located on the back of the sensor, as shown below. If needed, you can replace the battery with the 3.7V 300mAh Lithium Replacement Battery (PS-3296). To install the new battery:

1. Use a Phillips screwdriver to remove the screw from the battery door, then remove the door.
2. Unplug the old battery from the battery connector and remove the battery from the compartment.
3. Plug the replacement battery into the connector. Make sure the battery is properly positioned inside the compartment.
4. Place the battery door back in place and secure it with the screw.

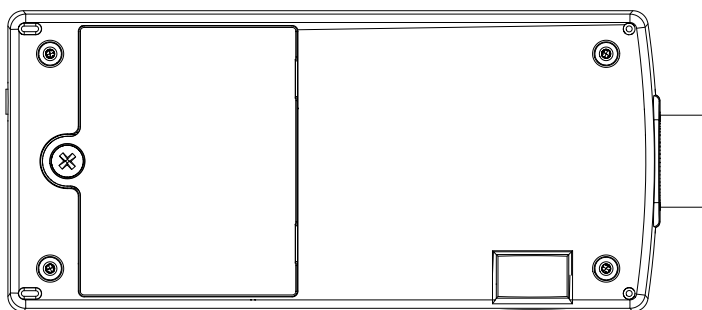

Figure 1: Placement of battery compartment.

After replacing the battery, make sure to dispose of the old battery properly per your local laws and regulations.

Troubleshooting

- If the sensor loses Bluetooth connection and will not reconnect, try cycling the ON button. Press and briefly *hold* the button until the LEDs blink in sequence, then release the button.
- If the sensor stops communicating with the computer software or tablet application, try restarting the software or application.
- If a communication problem persists, press and *hold* the ON button for about 10 seconds, then release the button and start the sensor in the usual way.
- If the above steps do not fix the connection, turn Bluetooth off and back on for your computer or tablet, then retry.

Conductivity probe maintenance

If readings become variable or well outside the expected range, clean the pins by pushing each pin into the eraser of a No. 2 pencil, then removing the pin from the eraser material. Repeat this cleaning process until no film appears around the puncture holes. Rinse and dry the conductivity probe before putting the sensor into storage. The probe fits into the Electrode Support (PS-3505).

Cleaning

When cleaning the probe, select an appropriate solvent for the contaminants to which the probe has been exposed.

- For general deep cleaning, use 0.1 M nitric acid.
- For oils, use hot water with dish detergent.
- For solutions containing lime or other hydroxides, use a 5-10% solution of hydrochloric acid. When a stronger cleaning solution is required, use concentrated hydrochloric acid mixed into 50% isopropanol.
- For solutions containing algae and bacteria, use chlorine bleach.

To clean the probe, dip or immerse the end of the probe in the cleaning solution, agitate for two to three minutes, and rinse first with tap water and then several times with distilled or deionized water.

Before taking any measurements after cleaning, immerse the probe in distilled water, gently tap out any trapped air bubbles, soak for at least an hour in distilled water, and recalibrate.

Software help

The SPARKvue, PASCO Capstone, and chemvue Help provide information on how to use this product with the software. You can access the help from within the software or online.

SPARKvue

Software: Main Menu  > Help

Online: help.pasco.com/sparkvue

PASCO Capstone

Software: Help > PASCO Capstone Help

Online: help.pasco.com/capstone

chemvue

Software: Main Menu  > Help

Online: help.pasco.com/chemvue

Specifications and accessories

Visit the product page at pasco.com/product/PS-4210 to view the specifications and explore accessories. You can also download experiment files and support documents from the product page.

Experiment files

Download one of several student-ready activities from the PASCO Experiment Library. Experiments include editable student handouts and teacher notes. Visit pasco.com/freelabs/PS-4210.

Technical support

Need more help? Our knowledgeable and friendly Technical Support staff is ready to answer your questions or walk you through any issues.

 Chat pasco.com

 Phone 1-800-772-8700 x1004 (USA)
+1 916 462 8384 (outside USA)

 Email support@pasco.com

Limited warranty

For a description of the product warranty, see the Warranty and Returns page at www.pasco.com/legal.

Copyright

This document is copyrighted with all rights reserved. Permission is granted to non-profit educational institutions for reproduction of any part of this manual, providing the reproductions are used only in their laboratories and classrooms, and are not sold for profit. Reproduction under any other circumstances, without the written consent of PASCO scientific, is prohibited.

Trademarks

PASCO and PASCO scientific are trademarks or registered trademarks of PASCO scientific, in the United States and in other countries. All other brands, products, or service names are or may be trademarks or service marks of, and are used to identify, products or services of, their respective owners. For more information visit www.pasco.com/legal.

Product end-of-life disposal



This electronic product is subject to disposal and recycling regulations that vary by country and region. It is your responsibility to recycle your electronic equipment per your local environmental laws and regulations to ensure that it will be recycled in a manner that protects human health and the environment. To find out where you can drop off your waste equipment for recycling, please contact your local waste recycle or disposal service, or the place where you purchased the product. The European Union WEEE (Waste Electronic and Electrical Equipment) symbol on the product or its packaging indicates that this product must not be disposed of in a standard waste container.

CE statement

This device has been tested and found to comply with the essential requirements and other relevant provisions of the applicable EU Directives.

FCC statement

This device complies with part 15 of the FCC Rules. Operation is subject to the following two conditions:

(1) This device may not cause harmful interference, and (2) this device must accept any interference received, including interference that may cause undesired operation.

Battery disposal



Batteries contain chemicals that, if released, may affect the environment and human health. Batteries should be collected separately for recycling and recycled at a local hazardous material disposal location adhering to your country and local government regulations. To find out where you can drop off your waste battery for recycling, please contact your local waste disposal service, or the product representative. The battery used in this product is marked with the European Union symbol for waste batteries to indicate the need for the separate collection and recycling of batteries.